



— BROCK SOLID® —

GRAIN HANDLING



Safeguarding Your Grain® Since 1957

Protecting Your Investment

When months of hard work go into producing a grain crop, trust it to the best in grain handling: Brock.

Brock Solid® is our guarantee of trusted reliability you can count on day in and day out. It's unmistakable quality, built to last year after year. And it's the same guarantee we founded the company on back in 1957.

Today, our dealers continue to uphold those standards, providing the superior service and support customers expect from Brock. Brock Solid means you can depend on them and us. Times may change, but our solid values are stronger than ever.

Whether you're a farmer storing your own grain or a commercial operation entrusted with safeguarding your customer's crops, Brock Solid delivers. Always has, always will.



Brock's Bucket Elevators are designed for commercial and farm-duty applications.

- Galvanized steel construction with painted weld seams.
- Capacities up to 60,000 bushels (1,524 metric tons) per hour.

Bucket Elevators



Elevator Head Platform wraps around the front of the head. This offers ample access for inspection and service. Galvanized steel, urethane or high-energy urethane liners for the head section are available based on your specific application.



Trunking Flanges are solid welded inside and out for durability and performance. Components are fixture-welded to ensure better accuracy and easy construction in the field. Trunking is always galvanized as the standard finish.

Grain Conveyors



Drag Conveyors are available in a range of styles and sizes to suit any operation's needs. Capacities range up to 42,800 bushels (1,087 metric tons) per hour.



GrainDrive™ T1000 Tube Conveyors are designed to install easier, work harder and last longer. Capacities range from to 4,000 to 10,000 bushels (102 to 254 metric tons) per hour.



SUPER-AIR® Pneumatic System uses positive pressure to help move grain to multiple bins with just one power source. Choice of 4-, 5- or 6-inch (102-, 127- or 152-mm) diameter systems and capacities ranging up to 2,250 bushels (57.2 metric tons) per hour.

Grain Sweeps



1500 Series Power Sweep - Designed for heavy duty on-farm usage, Brock's 1500 Series Bin Sweep offers zero-bin-entry safeguards for bins 15 to 60 feet (4.6 to 18.3 m) in diameter. Auger diameters: 8 or 10 inches (203 or 254 mm). Capacities range up to 5,500 bushels (140 metric tons) per hour.



1500 Series - Highly Refined Drive Wheel Patented open-style design. 16:1 reduction ratio maximizes longevity.



3500 Series Sweep - Adjustable Bin Wall Agitator



3500 Series Sweep - Designed for medium to heavy commercial duty, Brock's 3500 Series Bin Sweep features a unique, longer-lasting auger flighting. Bin diameters: 30 to 156 feet (9.1 to 47.5 m). Auger diameters: 12 or 16 inches (305 or 406 mm). Capacities range up to 10,000 bushels (254 metric tons) per hour.

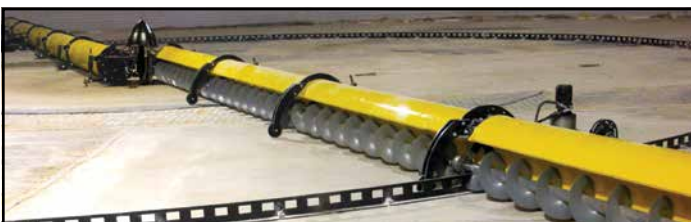

MAVERIK® 4000 Series Sweep - Proven for heavy commercial duty, Brock's MAVERIK® 4000 Series Sweep offers variable-speed technology, single- or dual-arm sweep options as well as hydraulically-powered augers and sprocket-and-ring track drive. Bin diameters: 60 to 132 feet (18.3 to 40.2 m). Auger diameter: 12 inches (305 mm). Capacities range up to 15,000 bushels (381 metric tons) per hour.

Distributors & Accessories



Distributors for Multi-Bin Sites - Brock's flat-back and swing-set distributors were developed to offer maximum power and optimum convenience on multi-bin sites. Select from a wide range of standard sizes to meet your specifications.



Spouting and Connections - Whether you need round or square spouting, all Brock spouting and connections feature strong flanges and clamps. These units are built from heavy-gauge steel with all-welded construction for unmatched convenience, performance and durability.

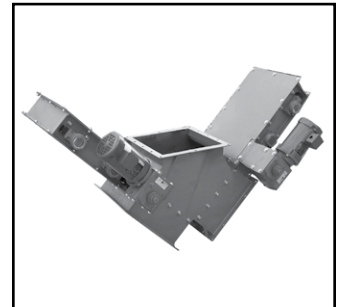

Slide Gates - Available in manual, electric or air-operated models, Brock's slide gates are built to last. These gates use cut-tooth rack and pinion, steel channel frames and welded steel construction throughout.



Distributor Turnheads are supported by two bearings instead of the standard single bearing. Cushion boxes and retarders are included to minimize grain damage at change of direction points.



Valves - Choose from manual, electric or air-operated valves in two-way, three-way or offset valve configurations. Over-flow valves are also available to provide relief when a bin or dryer is full.

A Full Line of Brock Solid® Solutions



Brock Solid® is our guarantee of trusted reliability you can count on day in and day out. It is the guarantee of unmistakable quality, built to last year after year. It is the same guarantee we founded the company on back in 1957. That focus on providing dependability has resulted in the full line of grain facility solutions that are available today. You will find the quality you have come to expect and the trusted integrity you deserve. Brock Solid delivers. Always has, always will.



Storage

- EVEREST® & On-Farm Grain Bins
- EVEREST® & Wet Holding Hopper Bins
- Temporary Storage
- Bin Access Doors
- Grain Aeration Floors



Structures

- Catwalks
- Bucket Elevator Towers & Stairways
- EVERLOC® Roof Mount System
- Support Towers
- Slot & Tab Construction



Drying & Conditioning

- Low-Profile Grain Dryers
- Tower Grain Dryers
- Centrifugal & Axial Fans
- Heaters
- Controls



— **BROCK SOLID** —

Safeguarding Your Grain® Since 1957

BROCK GRAIN SYSTEMS

A Division of CTB, Inc.

A Berkshire Hathaway Company

Phone: +1 866.658.4191

www.brockgrain.com

Email: sales@brockgrain.com

BR-2277/202203